

# SMITHS LANE

CLYDE NORTH

DESIGN GUIDELINES  
FEBRUARY 2020



---

**CONTENTS**

VISION & PROCESS	1
HOME STYLE GUIDE	2
SITING THE HOME	2
FAÇADE, MATERIALS & FINISHES	3
GARAGES & DRIVEWAYS	3
ROOFING & EAVES	4
FENCING	4
LETTER BOXES & ANCILLARY	5
LANDSCAPING & RETAINING YOUR LOT	6
GOOD NEIGHBOUR GUIDE	8
SUBMISSION CHECKLIST	9
APPENDIX 1: DESIGN ASSESSMENT APPLICATION FORM	11
APPENDIX 2: FAÇADE MATERIAL ANALYSIS FORM	14
APPENDIX 3: FENCING DESIGN GUIDE	16
APPENDIX 4: FENCING CONSENT FORM	33
APPENDIX 5: LANDSCAPE REQUEST FORM	35



## VISION & PROCESS

The aim of the Smith Lane Design Guidelines is to create a coherent vision for this new community. These design guidelines are not intended to restrict or limit the home design on your lot. Rather, the guidelines have been designed to ensure all homes at Smiths Lane are built to a high architectural standard and encourage a variety of housing styles that are sympathetic to the local streetscape and reflect the preferred character and quality of Smiths Lane.

The key design elements that purchasers and home builders are encouraged to address include:

- Siting and orientation
- Architectural style and built form
- Landscaping and fencing
- Sustainability

All new buildings and landscape designs must be consistent with the Design Guidelines.

Before any work commences on your site, you must obtain approval of your plans from the Design Review Panel (DRP).

The following summary will assist you in navigating the building approval process at Smiths Lane.



Artist Impression.

### Step 1 – Land purchase

Purchase your selected allotment from Mirvac.

### Step 2 – Design your home

Ensure your architect, builder and designer are aware of the requirements within the Smiths Lane Design Guidelines as well as any Restrictions and Building Envelope Plans on the Plan of Subdivision. Make sure they are aware of the landscaping requirements in order to qualify for the front lot landscaping package. You should also ensure that you have complied with any applicable building codes, Council by-laws and other local authority requirements.

### Step 3 – Submit plans for approval to the DRP

Submit your house design and completed Design Assessment Form at the Smiths Lane Design Portal <https://portal.smithslane.mirvac.com/>. Ensure your submission contains all the required information (as set-out in the checklist). Approval can be expected within 10 working days providing all documents have been submitted and they comply with the Smiths Lane Design Guidelines. In the event of non-compliance, structured feedback will be provided to facilitate approval. If all feedback has been addressed, you should expect approval within 10 working days of resubmitting.

### Step 4 – Building permit application (by your builder)

A Building Permit must be obtained from either the City of Casey or a licenced surveyor. Your registered building surveyor will require your home design to comply with the Restrictions on the Plans of Subdivision and will require evidence of DRP approval (usually stamped plans). If any further design modifications are made, you will be required to resubmit plans to the DRP for reassessment.

### Step 5 – Construction

Once received, a Building Permit allows you to commence construction. In accordance with the Contract of Sale, construction of your home must commence within 12 months from the date of settlement of your lot. Completion of your home must be within 12 months of build commencement. Landscaping must be completed within 3 months of Certificate of Occupancy unless you take up the Smiths Lane Front Lot Landscaping Package.

### Step 6 – Certificate of occupancy

Subsequent to Certificate of Occupancy; all kerb/sidewalk rectification works must be completed within 90 days. Your driveway and crossover must be completed before you move in to your new home.

### Step 7 – Smiths Lane landscaping package

Please refer to the Smiths Lane Landscape Request Form (Appendix 5) for details on how to be eligible for the Front Lot Landscaping Package.



## HOME STYLE GUIDE

Contemporary Australian architecture will best define the style of homes at Smiths Lane. This will be achieved through simple forms and well-proportioned façade elements combined with controlled use of architectural styles, materials and colours selected to reflect the character of the home location within the Smiths Lane Estate.

The guidelines will not restrict reproductive styles such as Victorian, Edwardian or Federation forms or other architectural styles. Each home built at Smiths Lane will undergo a review by the Design Review Panel (DRP) based on its adherence to the guidelines set-out below and how it relates to the overall vision for Smiths Lane. The Mirvac Design Review Panel will exercise its discretion and will assess each case on its architectural merit.

## SITING THE HOME

- Buildings should aim to be orientated to take advantage of passive solar access and ventilation.
- To site the home, Building Envelope Plans (BEP) have been prepared for all lots over 300 square metres where the Small Lot Housing Code is not applied. Please refer to the relevant plan of subdivision for individual lot building envelopes. The dwelling and garage should be contained within the building envelope.
- Building outside of the building envelope is subject to approval from Council and the DRP.
- Homes should be set back a minimum of 4m and a maximum of 6m from the front boundary unless the Small Lot Housing Code applies or the Building Envelope allows.
- Front entries should be clearly visible from the street and must include a covered veranda, porch or portico or other integral entry feature which may encroach 1.5m into the front setback to provide a sense of address.
- For corner lots, a minimum setback of 2m to the secondary street frontage is required unless the Small Lot Housing Code applies.
- Garages must be setback a minimum of 5.5m from the front boundary and a minimum of 1m behind the front wall of the home.
- A Build to Boundary Zone must only apply to one side boundary. Only one of these zones can be utilised per lot in relation to the location of the crossover provided to that lot, unless the Small Lot Housing Code applies.
- It is recommended that the side setback is on the side of the lot not containing the garage.
- Large, bulky buildings with unarticulated wall surfaces will not be approved.

## FAÇADE, MATERIALS & FINISHES

- Home façades must incorporate a minimum of two and maximum of four materials or finishes. One material or finish may constitute up to 70% of the overall front façade.
- The use of natural materials, non-reflective finishes and muted colours is encouraged. The main colours of the façade should be light, natural and earthy. Highlight materials such as timber or natural stone are encouraged to articulate design elements.
- Bright or fluorescent colours will not be approved, unless they are deemed complementary to the design of the dwelling at the discretion of the DRP.
- Homes may be approved with one material finish subject to design and architectural merit at the discretion of the DRP.
- Homes must avoid replicating an identical façade to another dwelling within three lots in either direction on the same side of the street or within three lots on the opposite side of the street.
- In the event that more than one application of the same façade design has been submitted for lots within close proximity, consent will be given to the first complete application to be received.

### Articulation on corner lots

Design and articulation of corner lots must comply with the below controls;

- A feature window must be provided to the secondary street frontage of your home within the first four (4) metres from the front façade. Highlight windows are discouraged.
- Double storey dwellings must provide variation in materials between the upper and lower storeys to articulate the corner of both façades.
- Design elements (such as verandas, detailing, feature windows and materials) used on the primary frontage must continue on that part of the secondary frontage visible to the public realm.
- Double storey homes on corner lots must have a minimum 20% glazing to the upper floor that faces the secondary frontage, measured as an area of the upper floor wall elevation.
- Highly reflective window tints are not permitted to publicly visible façades.
- Lightweight infills are not permitted above any window openings along façades directly visible from the street or public open space. Infills are permitted above garage doors where the colour matches the garage door colour.
- External security blinds and roller shutters are not permitted.
- Front security doors must complement the style of the home and not dominate the façade.

## GARAGES & DRIVEWAYS

- Garage doors must be a sectional door in a timber, timber look or Colorbond finish. Open carports will not be approved.
- The width of the garage door opening can be no more than 40% of the width of the primary lot frontage, unless:
  - The dwelling is double storey in nature in which the width of the garage opening can exceed 40% of the primary frontage with approval by the Design Review Panel; or
  - The lot is irregular in nature in which case the garage opening cannot exceed 40% of the width of the lot as taken at the primary building frontage; or
  - As otherwise approved by the Design Review Panel at its discretion based on the architectural merit of the proposed dwelling.
- Driveways must be constructed from a hard surface material such as exposed aggregate concrete, segregated brick, slate, natural stone pavers or coloured through concrete. Plain concrete is not permitted.
- Special consideration from the DRP will be given to permeable driveway outcomes based on material selection and architectural merit.
- The driveway is not to exceed the width of the garage opening plus allowance for a front entry pathway.
- Driveway widths must match back to the width of the constructed vehicle crossover at the title boundary.
- Where garages are located on the allotment boundary, a 500mm minimum landscaped garden bed is required between the driveway and the allotment boundary.
- Only one crossover and driveway is permissible per allotment (unless otherwise approved by the DRP and Council on corner allotments on application). Your driveway must align exactly with the crossover provided by Mirvac and must be constructed before occupation of the home.
- Relocation of your crossover requires DRP approval. Related costs must be paid by the property owner prior to construction. Relocation is at Mirvac's total discretion and is not always possible due to the status of the civil works program, layout of streets, street trees and underground service. Should you request to have your crossover relocated or an additional crossover installed (corner lots only), please email us at vic.settlements@mirvac.com

## ROOFING & EAVES

- Hip and gable roofs must have a minimum roof pitch of 22 degrees.
  - Skillion roofs must have a minimum pitch of 10 degrees.
  - Flat roof forms that have a pitch less than 15 degrees must be concealed with parapet walls from the public realm.
  - Single storey homes with a pitched roof must include minimum 450mm eaves to all sides of the home that face a street or public open space and return for a minimum of 4m.
  - Double storey homes with a pitched roof must include a minimum 450mm eave to all sides of the dwelling on the upper storey.
  - Eaves are not required to wrap around garage walls on the boundary or to parapet walls
- The roof must be finished in one of the following materials and the colour must be complementary to the design of the home:
- Matte Colorbond finish (or similar)
  - Non-reflective corrugated metal deck roofing
  - Terracotta, Concrete, Clay or Slate low-profile tiles
  - Lighter roofing colours are encouraged to reduce heat absorption in summer and all design outcomes are at the discretion of the DRP.

## FENCING

- Construction of front lot fencing, side boundary fencing, rear fencing and return/wing fencing is by the purchaser and not the developer. Specifications are provided at Appendix 3.
- Corral fencing forward of the return fencing between allotments is mandated. It will be provided in the landscape package should you choose to uptake it, otherwise must be constructed at your own cost. This corral fencing is to be setback 1m from the front title boundary. Corral fencing forward of return fencing along secondary street frontage will not be permitted. Specifications are provided at Appendix 3 (fence type LA002/003).
- Side and rear boundary fencing must be 1.8m high timber paling. Specifications are provided at Appendix 3 (fence type LA006).
- The return fencing to the dwelling must be permeable and must return a minimum 1m behind the front wall of the home and 4m on a corner lot. Specifications are provided at Appendix 3 (fence type LA007/008).
- On corner lots, side boundary fencing along the secondary street frontage for corner lots must be 1.8m high timber paling, lapped and capped with exposed posts. This fence must return to the side wall of the home a minimum of 4m behind the front wall. Corral fencing is not permissible forward of this return along the secondary street fronting. Specifications are provided at Appendix 3 (fence type LA005).
- Feature fencing will be delivered on lots adjoining the transmission easement and may be delivered on lots adjoining local parks or other areas within Smiths Lane. This will be delivered by Mirvac. Specifications are provided at Appendix 3 (fence type LA004).
- Front fencing is allowable. Any front fencing must be a maximum of 1.2m high and be constructed from a feature, high-quality material to complement the style of the home and corral fencing. Approval is at the discretion of the DRP and approval must be obtained prior to installation. The inter lot corral fencing between lots must be extended by the owner to meet the front fencing at the title boundary.
- Where purchaser fencing is to be installed on retaining walls delivered by Mirvac in the rear or side of lots, fencing must be installed as per the detail provided in the engineering plans.

## LETTER BOXES & ANCILLARY

- Letter boxes must be contemporary in style and constructed from masonry, timber or painted metal, sized as per Australia Post recommendations and match in with the design of the home.
- Single post supporting letterboxes will not be approved.
- Dwelling services such as clothes lines, air conditioning units, satellite dishes, antennae and water tanks must be located away from direct view lines from the street or public realm.

- Any outbuilding less than 10sqm must be clad in an approved colour to compliment the dwelling.
- Any outbuilding greater than 10sqm must be constructed so that the external appearance matches the main dwelling in colours, materials and style.
- Rubbish bins, recycling bins and any other garbage disposal containers are to be stored away from public view.
- Dwellings must be connected to all available infrastructure such as the National Broadband Network and the recycled water network.



## LANDSCAPING & RETAINING YOUR LOT

Mirvac are offering a front lot landscaping package to eligible purchasers who comply with the Front Lot Landscaping Package Terms and Conditions. There are 4 designs to choose from. These designs are on display at the Smiths Lane Sales Experience Centre.

Prior to Mirvac installing your complimentary Front Lot Landscaping Package you must ensure the following is complete to the satisfaction of Mirvac:

- Pre-works must be completed to accommodate an irrigation system:
  - A 90 mm PVC pipe or similar is required to be installed under the driveway setback at a minimum of one (1) metre from the front boundary. A minimum of two external taps are to be installed, one in the rear yard and one in the front yard on the side of the dwelling adjacent to the side gate/fence.
  - An external power point must be installed adjacent to the external tap located in the front yard.



- Front path treatment:
  - The front garden package does not include a front garden path. The installation of a path is the responsibility of the owner should you choose to do one. The path must be installed prior to receiving the Front Lot Landscaping Package.
- General construction items:
  - Driveway complete.
  - All required earthworks complete and landscape area levelled to 100mm below driveway level in preparation for top soil.
  - Retaining walls complete (if applicable) and in accordance with the Design Guidelines. (If batter is to be used, it should not be more than 1:6 gradient - consult your builder or architect).
  - All site rubbish removed.
  - Garage door installed.
  - Porch and front paths (if applicable) complete.
  - Rear, side and return fencing installed (Mirvac will install the front lot fencing as part of the package).
  - Approved letterbox installed.
  - Drainage infrastructure installed (as required).
  - NBN Co. street connection completed.
  - Clear access to area in which works will be undertaken.

Should you choose not to take up the complimentary Front Lot Landscaping Package from Mirvac the following landscaping guidelines apply:

- Front landscaping must be completed within 3 months of occupation of the home.
- The front garden must include a canopy tree that is a minimum height of 1m at installation and 4m in diameter at maturity. The following list can provide some guidance on appropriate tree selection:

Botanical name	Common name	Mature size (HxW)
<i>Backhousia citriodora</i>	Lemon Scented Myrtle	8m x 4m
<i>Callistemon 'Kings Park Special'</i>	Kings Park Special Bottlebrush	4m x 2m
<i>Calodendrum capons</i>	Cape Chestnut	10m x 6m
<i>Corymbia citriodora 'Scentuous'</i>	Dwarf Lemon Scented	7m x 5m
<i>Corymbia eximia nana</i>	Yellow Bloodwood	7m x 5m
<i>Eucalyptus Caesia 'Silver Princess'</i>	Silver Princess	5m x 4m
<i>Koelreuteria paniculata</i>	Golden Rain Tree	6m x 4m
<i>Lagerstroemia indica x fauriei 'Tonto'</i>	Tonto Crepe Myrtle	3m x 3m
<i>Lagerstroemia indica x L. Fauriei 'Tuscarora'</i>	Tuscarora Crepe Myrtle	6m x 5m
<i>Magnolia Grandiflora 'Little Gem'</i>	Little Gem Magnolia	6m x 3m
<i>Olea europaea 'Swan Hill'</i>	Swan Hill Olive	8m x 6m
<i>Pistacia chinensis</i>	Chinese Pistachio	8m x 6m
<i>Tristanopsis laurina 'Luscious'</i>	Luscious Kanooka	8m x 5m
<i>Gleditsia triacanthos var. inermis 'Elegantissima'</i>	Compact Honey Locust	4m x 3m

- Any landscape areas visible from the street or open space must always be maintained, kept neat and tidy with no excessive weed growth. This includes nature strips which are the responsibility of the lot owner.
- Any retaining structures must be no more than 1 metre in height between a dwelling and a street or public space.
- Any cutting and filling deeper than 1 metre must use either planted and landscaped embankments (maximum 1:6 gradient), or a combination of a series of retaining structures (maximum 1 metre high steps) with planted embankments or terracing.
- The existing slope is not to be modified in any way that will affect the structural integrity or any structure erected on an adjoining lot.
- The installation of any new retaining walls that will structurally affect the existing walls, building platforms or batters, and any modification of the lot's existing batters and retaining walls, is only permitted once you have obtained professional advice from a structural engineer and received all relevant approvals. A copy of such advice and approvals must be provided to the Design Review Panel.
- Impermeable hard surface materials must not exceed 60% of the front garden area including the driveway and front path.
- Artificial turf must not be used in the front lot landscaping.



## GOOD NEIGHBOUR GUIDE

### Vehicles

- Vehicles of any kind are not permitted in your front yard, on footpaths, verges or vacant land. Your driveway can be used to park cars or light utilities but not for long term storage of boats, caravans or containers.
- To keep thoroughfares clear, trucks or similar vehicles cannot be parked on the roadway for extended periods of time.
- Trucks, trailers, boats and caravans must be parked off street and out of public view.

### Gardens

- Front gardens should be kept tidy with grass (including verge) mowed regularly, gardens weeded, and plants thriving for an evergreen look and feel.

### Waste

- Rubbish bins should always be kept behind fences or screened from both public and neighbouring allotment views; except for the day of rubbish collection.

### Laundry

- Clothes drying facilities must be located away from or screened from public view.

### Window fittings

- Homes should be fitted with curtains, blinds or shutters. Please ensure visually prominent security screens (e.g. diamond grills); or vertical blinds are not installed on doors or windows facing any street frontage.

### Construction

- Mirvac will be trialling different waste removal systems with home builders to ensure that waste is kept to a minimum and recycled where possible. The aim is to minimise the dumping of material in landfill.
- During home construction, no rubbish can accumulate on the lot unless stored in a skip or bin and trade vehicles or delivery vehicles must not park on verges, footpaths, nature strips or park reserves.
- Building materials are not permitted to be delivered or stored on the nature strip or anywhere outside the title boundary.

### Other

- No advertising signage is permitted on either vacant land or an occupied allotment.



# SUBMISSION CHECKLIST

## SITE PLAN CHECKLIST

- North point
- Scale (1:100, 1:200)
- Lot boundaries, title boundaries and setout locations; building footprint (outline) and easements
- Slab levels
- Site contours and site levels
- Building setback dimensions (from all boundaries)
- Location of driveway and crossover and front path
- Location of retaining walls (where applicable)
- Location of swimming pools (where applicable)
- Location of services (hot water service, water tanks and air conditioning)
- Connection to recycled water indicated
- BAL rating
- Location of all outbuildings

## FLOOR PLAN CHECKLIST

- North point
- Scale (1:100, 1:200)
- Finished floor levels
- All internal rooms and spaces
- Internal floor area
- Internal garage area
- Smart wired in accordance with NBN requirements
- Garage dimensions
- Site coverage
- Site permeability

## ELEVATIONS

- Scale (1:100, 1:200)
- Natural ground level
- Finished ground level
- Building heights relative to ground level
- Materials and finishes
- Roof pitch and materials
- Locations of services (hot water services, water tanks and air conditioning)

## SECTIONS

- Scale (1:100, 1:200)
- Natural ground level
- Finished ground level
- Cut and fill levels
- Ceiling heights
- Building heights relative to ground level
- Materials and finishes
- Roof pitch and materials

## MATERIALS & FINISHES SCHEDULE

- Façade materials analysis table
- All buildings façades materials and colours
- All roof colours and materials
- All fencing including any front fencing finishes and colours

## LANDSCAPE PLAN CHECKLIST

- Landscape Request Form (Appendix 5) if applicable
- Driveway materials and finish
- Entry path if applicable
- Fencing line, materials and colours
- Established tree locations and species if applicable
- Hot water service location
- Water tank locations
- Letter box location and design

For more details, visit the Smiths Lane Design Portal at <https://portal.smithslane.mirvac.com/>

### IMPORTANT NOTICE

The content of this brochure was produced prior to completion, and prior to the receipt of final planning approvals. Photographs, diagrams and artist's impressions are a guide only. The information provided in this brochure, including those images, is believed to be correct at the time of printing but will change as the development and planning approvals proceed. Changes will also be made during the development of the project, specifications and details may be changed without notice. The Project Information and the information contained in this brochure is preliminary only and subject to change without notice as the development progresses. Purchasers must rely on their own continuing enquiries. This brochure and its contents is not an offer or a contract. Mirvac expressly excludes any and all liability relating to, or resulting from, the use of or reliance on, any information contained in this brochure by any person. Current at 01 February 2020.

APPENDIX 1:  
DESIGN ASSESSMENT  
APPLICATION FORM



## DESIGN ASSESSMENT APPLICATION FORM

Lot Number \_\_\_\_\_ Date: \_\_\_\_\_

### Owner's Contact Details:

Owner's Name \_\_\_\_\_ Preferred Contact No. \_\_\_\_\_  
Email \_\_\_\_\_  
Address \_\_\_\_\_  
Suburb \_\_\_\_\_  
Postcode \_\_\_\_\_ State \_\_\_\_\_

The main point of contact for all design assessment correspondence will be your **builder/architect**.  
Please provide contact details below:

### Contact Details for Builder/Architect:

Company \_\_\_\_\_  
Main Contact Name \_\_\_\_\_ Ph. \_\_\_\_\_  
Email \_\_\_\_\_  
Address \_\_\_\_\_  
Suburb \_\_\_\_\_  
Postcode \_\_\_\_\_ State \_\_\_\_\_

**Front of Lot Landscaping - please select one of the following:**

I consent to Mirvac completing the landscaping to the front of my lot and I will provide a completed **Landscape Request Form** nominating my preferred landscape design to Mirvac as part of this Design Assessment Application.

or

I plan to design and install my own landscaping to the front of my lot and my builder/ architect will provide **Landscape Plans** as part of my Design Assessment Application. I understand landscape works to the front of my lot must be completed within 3 months of the issue of a Certificate of Occupancy.

**By submitting this application form to Mirvac I acknowledge the following:**

- My building designer is aware of the **Smiths Lane Design Guidelines**.
- I understand that my house design must comply with all sections of the **Smiths Lane Design Guidelines**.
- Approval by the Design Review Panel (DRP) does not guarantee my design complies with the requirements of the **Restrictive Covenants and City of Casey Council or the Building Regulations (Rescode)**.
- My house design will need to be re-submitted for assessment under the **Smiths Lane Design Guidelines** if the design changes as a result of the requirements of the Building Surveyor.

Signed (owner) \_\_\_\_\_ Date: \_\_\_\_\_

APPENDIX 2:  
FAÇADE MATERIAL  
ANALYSIS FORM

## FAÇADE MATERIALS ANALYSIS TABLE

This table must be submitted with your Design Assessment Application.

Lot Number \_\_\_\_\_ Application Ref Number \_\_\_\_\_

Table 1 is applicable to a **primary** street façade only to demonstrate that the façade complies with the Home Style Guide of the Smiths Lane Design Guidelines.

Table 1

	Material	Material Colour	Material Area (m2)	Area as Proportion of Whole Façade (%)
Material 1				
Material 2				
Material 3				
Material 4				
		<b>Total Façade Area</b>	<b>m2</b>	<b>100%</b>

Note: Principal façade material and colour to be no more than 70% of total façade area (excluding door/window openings)

Table 2 is only applicable if your lot has a **secondary** street façade or where the secondary façade fronts public open space. Complete this table to demonstrate that the secondary façade complies with the Home Style Guide of the Smiths Lane Design Guidelines.

Table 1

	Material	Material Colour	Material Area (m2)	Area as Proportion of Whole Façade (%)
Material 1				
Material 2				
Material 3				
Material 4				
		<b>Total Façade Area</b>	<b>m2</b>	<b>100%</b>

Note: Principal façade material and colour to be no more than 70% of total façade area (excluding door/window openings)

APPENDIX 3:  
FENCING DESIGN GUIDE

# SMITHS LANE

## FENCING DESIGN GUIDE

### DETAIL DESIGN

#### DRAWING REGISTER

M19007-02-LA-00A	COVER PAGE & DRAWING REGISTER
M19007-02-LA-001	LOCATION PLAN
M19007-02-LA-002	FENCING DETAILS - SHEET 1
M19007-02-LA-003	FENCING DETAILS - SHEET 2
M19007-02-LA-004	FENCING DETAILS - SHEET 3
M19007-02-LA-005	FENCING DETAILS - SHEET 4
M19007-02-LA-006	FENCING DETAILS - SHEET 5
M19007-02-LA-007	FENCING DETAILS - SHEET 6
M19007-02-LA-008	FENCING DETAILS - SHEET 7

**WARNING**



Services shown on this drawing are approximate only. The exact location is to be confirmed on site by contractor prior to commencement of work.

[www.1100.com.au](http://www.1100.com.au)

**NOTES**

Check all dimensions and site conditions prior to commencement of any work, the purchasing or ordering of any materials, fitting, plant services or equipment and the fabrication of any components.

Do not scale drawings - refer to figured dimensions only. Any discrepancies shall immediately be referred to the landscape architect for clarification.

All drawings may not be reproduced or distributed without prior permission from the landscape architect.

DATE	REV	AMENDMENTS
16.10.2019	A1	DETAIL DESIGN

**ASPECT Studios™**

ASPECT Studios Pty Ltd  
 Level 4, 160 Queen Street  
 Melbourne VIC 3000  
 Australia  
 T 03 9417 6844  
 F 03 9417 6855  
 www.aspect-studios.com  
 melbourne@aspect-studios.com  
 ABN 11 120 219 561

**MELBOURNE**

**CLIENT**

**MIRVAC**  
 Level 5, Building Q3  
 6 Riverside Quay  
 Southbank VIC 3006

**PROJECT**

Smiths Lane  
 Fencing Design Guide

**STATUS**

**DETAIL DESIGN**  
 NOT FOR CONSTRUCTION

**DRAWING**

Cover Page & Drawing Register

**DRAWN** HF  
**CHECKED** AMP  
**SCALE A1 | SCALE**  
**NTS**  
**DRAWING NO.** M19007-02- LA-00A  
**REVISION** A1

NOTE:  
TO BE CONSTRUCTED BY PURCHASER IF THEY  
DO NOT TAKE UP THE LANDSCAPE PACKAGE

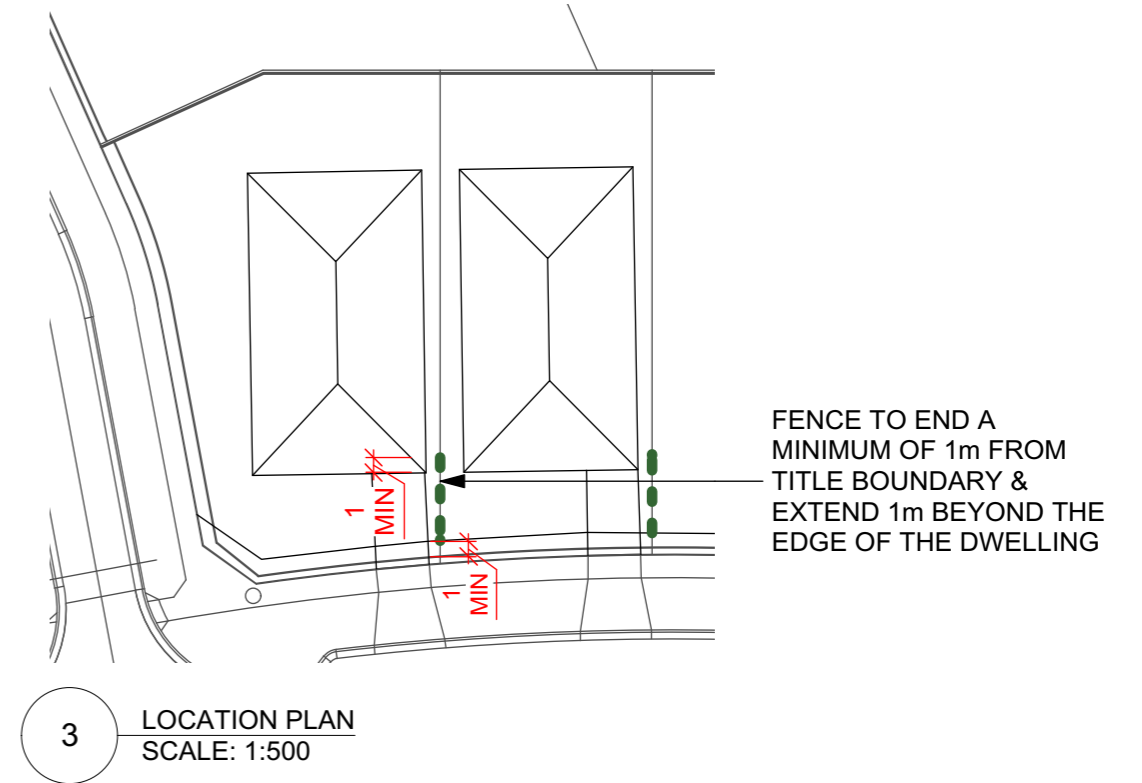
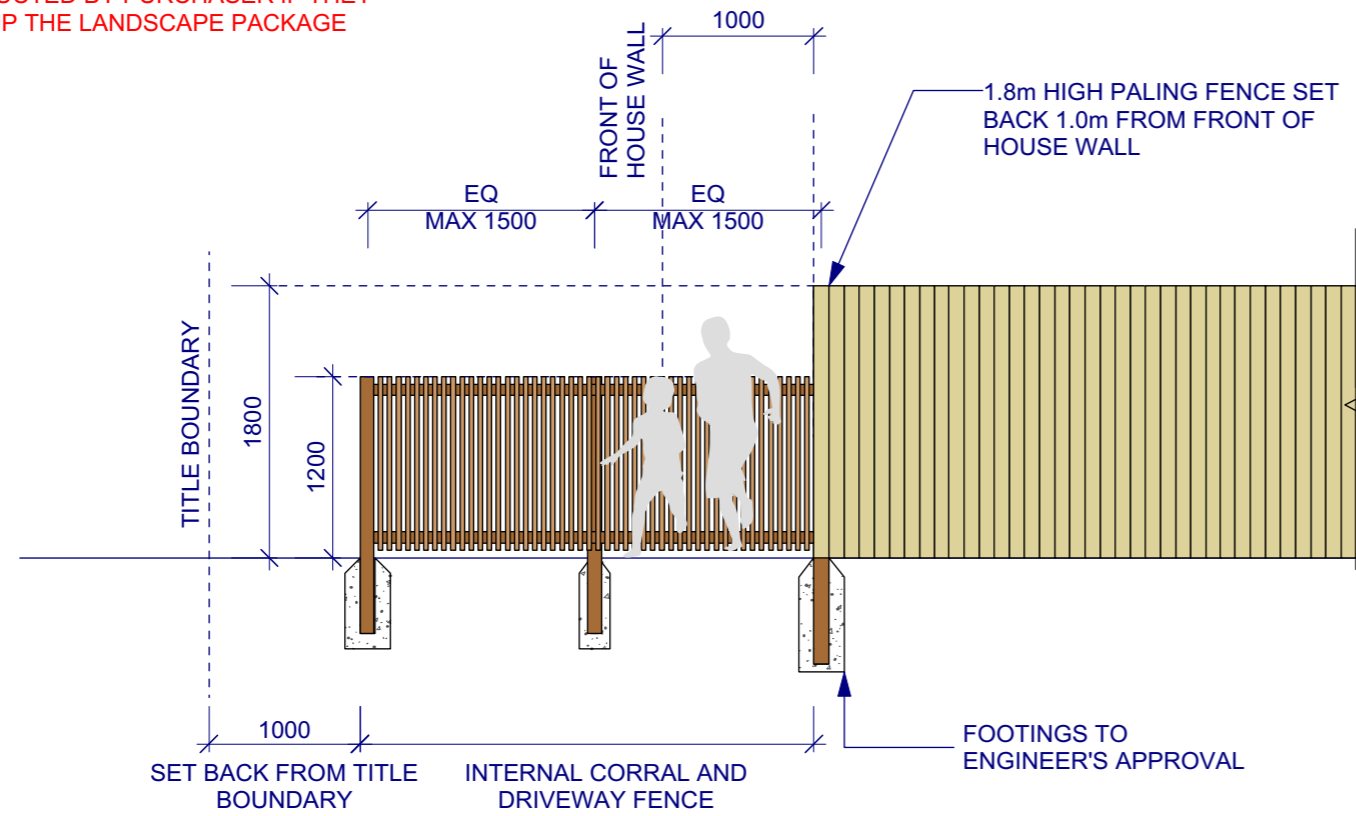

1 Internal Corral and Driveway Fence - Elevation  
SCALE: 1:50

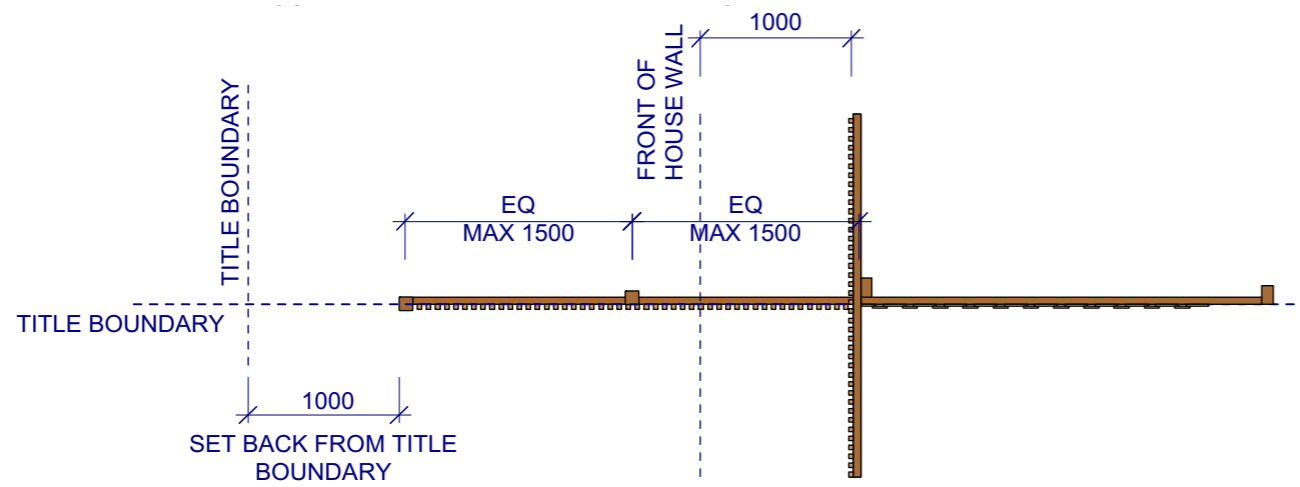

2 Internal Corral and Driveway Fence - Plan  
SCALE: 1:50



NOTES  
Check all dimensions and site conditions prior to commencement of any work, the purchasing or ordering of any materials, fitting, plant services or equipment and the fabrication of any components.  
Do not scale drawings - refer to figured dimensions only. Any discrepancies shall immediately be referred to the landscape architect for clarification.  
All drawings may not be reproduced or distributed without prior permission from the landscape architect.

DATE	REV	AMENDMENTS
16.10.2019	A1	DETAIL DESIGN

**ASPECT Studios™**  
ASPECT Studios Pty Ltd  
Level 4, 160 Queen Street  
Melbourne VIC 3000  
Australia  
T 03 9417 6844  
F 03 9417 6855  
www.aspect-studios.com  
melbourne@aspect-studios.com  
ABN 11 120 219 561

CLIENT  
**MIRVAC**  
Level 5, Building Q3  
6 Riverside Quay  
Southbank VIC 3006

PROJECT  
Smiths Lane  
Fencing Design Guide

STATUS  
DETAIL DESIGN  
NOT FOR CONSTRUCTION

DRAWING  
Fencing Details  
Sheet 1

DRAWN  
HF  
CHECKED  
AMP  
SCALE A1 | SCALE  
1:50  
DRAWING NO.  
M19007-02- LA-002  
REVIS  
A1

**NOTE:**  
TO BE CONSTRUCTED BY PURCHASER IF THEY  
DO NOT TAKE UP THE LANDSCAPE PACKAGE

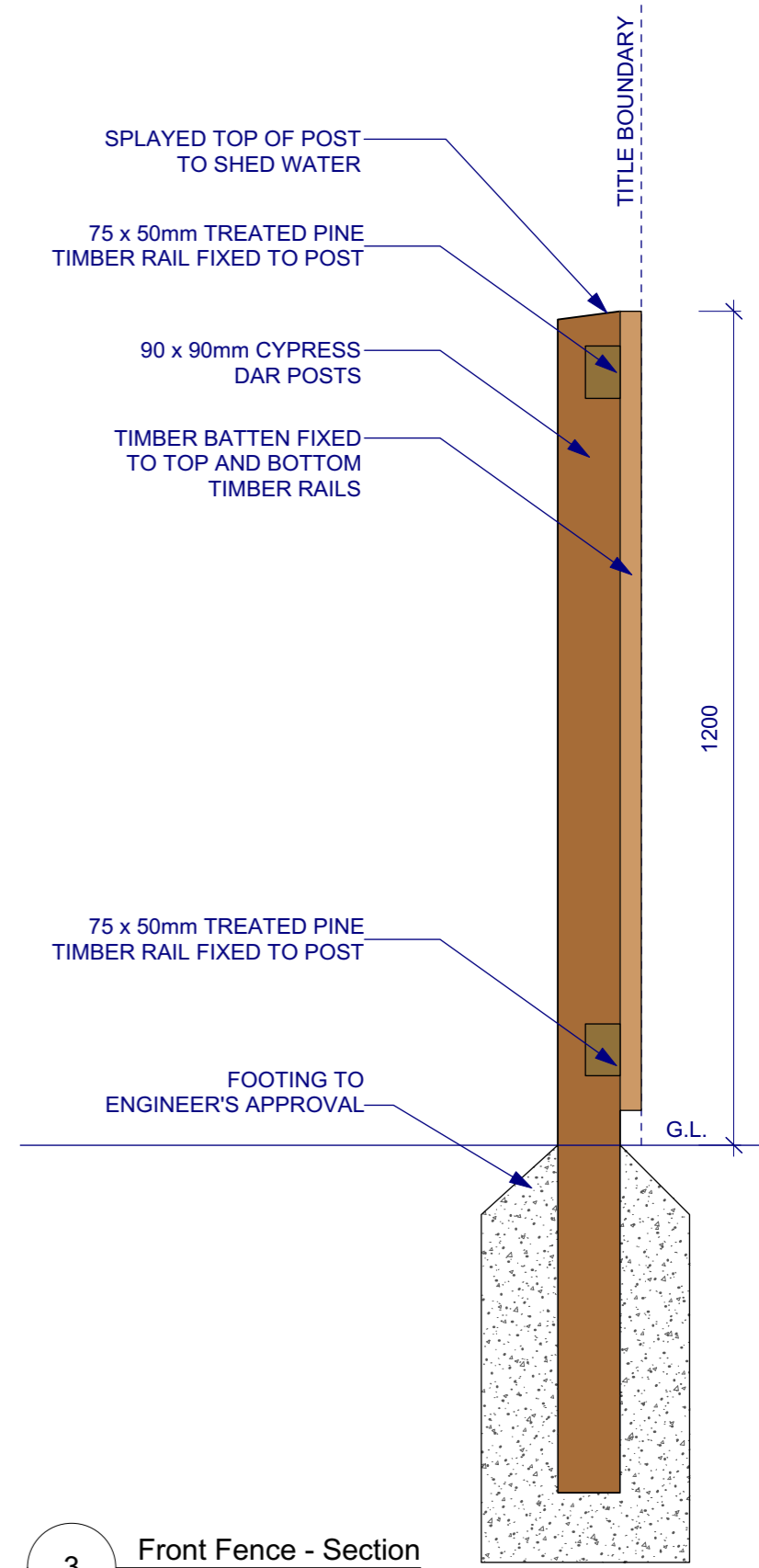
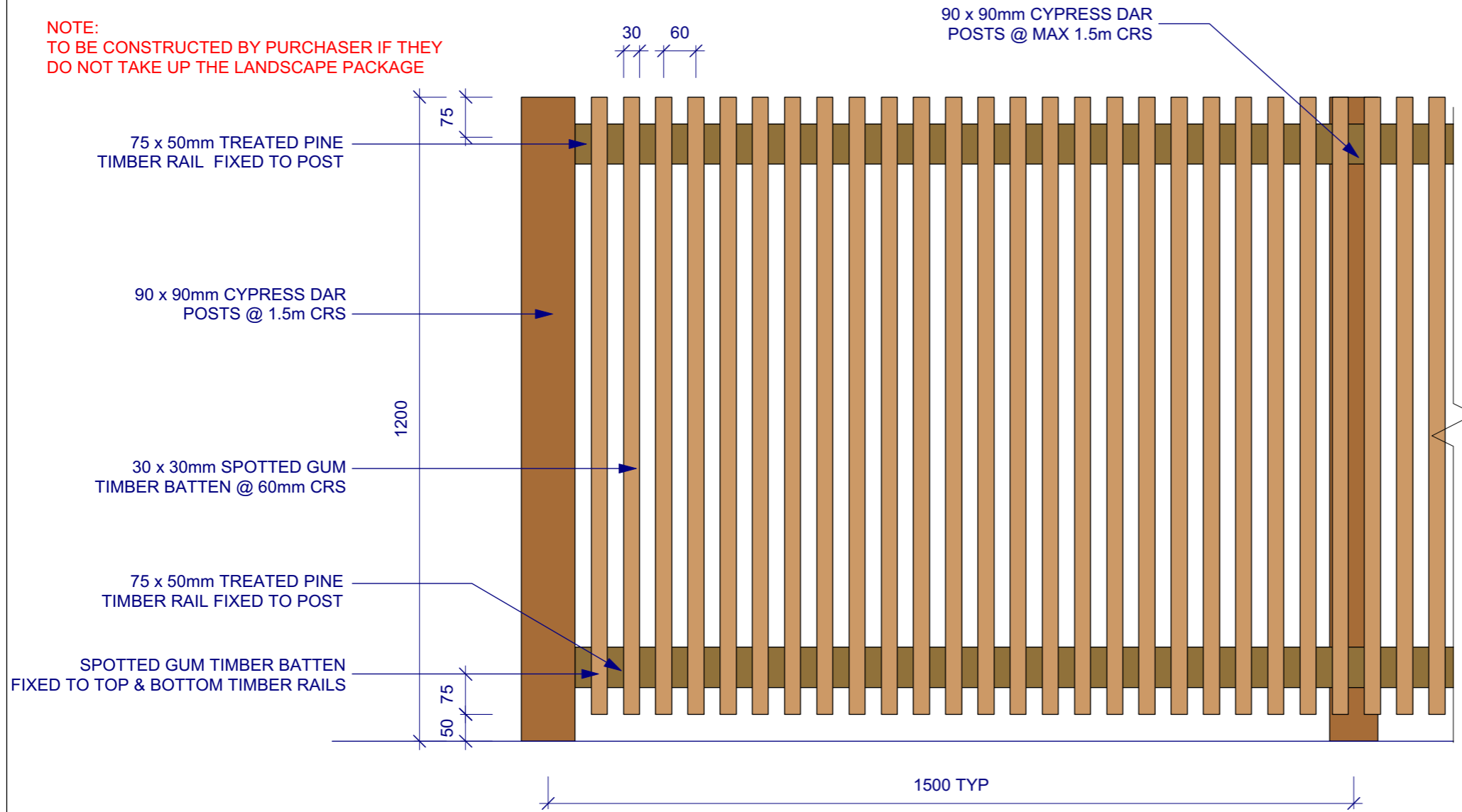

1 Internal Corral and Driveway Fence - Elevation  
SCALE: 1:10

3 Front Fence - Section  
SCALE: 1:10

2 Internal Corral and Driveway Fence - Plan  
SCALE: 1:10

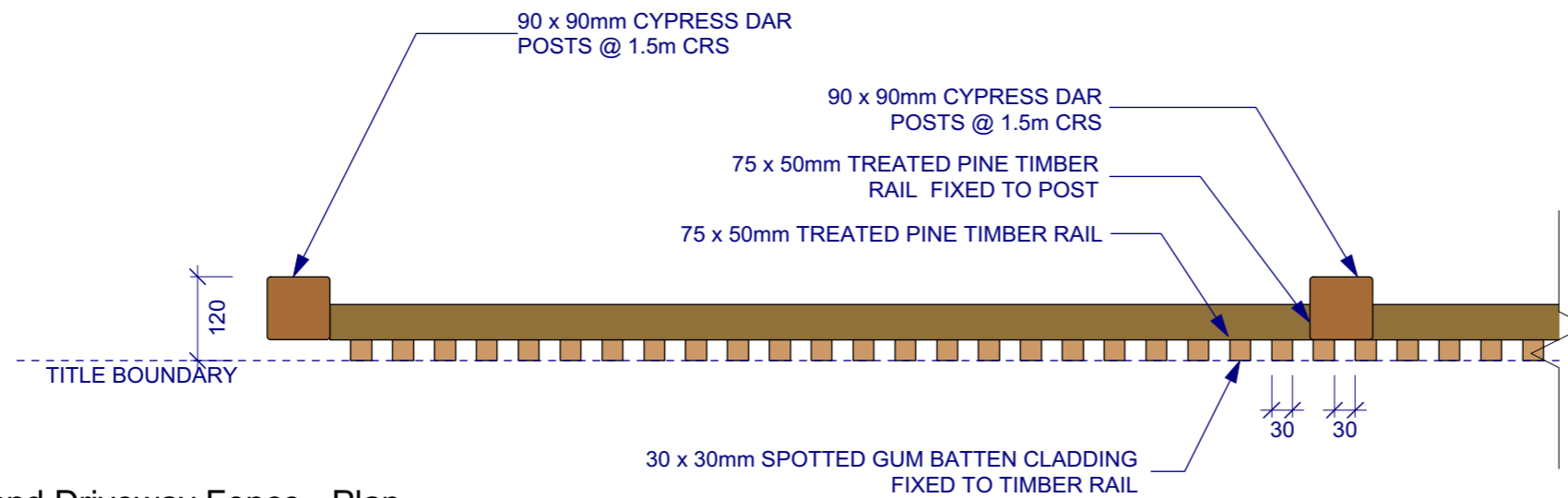

**NOTES**  
Check all dimensions and site conditions prior to commencement of any work, the purchasing or ordering of any materials, fitting, plant services or equipment and the fabrication of any components.  
Do not scale drawings - refer to figured dimensions only. Any discrepancies shall immediately be referred to the landscape architect for clarification.  
All drawings may not be reproduced or distributed without prior permission from the landscape architect.

DATE	REV	AMENDMENTS
16.10.2019	A1	DETAIL DESIGN

**ASPECT Studios™**  
ASPECT Studios Pty Ltd  
Level 4, 160 Queen Street  
Melbourne VIC 3000  
Australia  
T 03 9417 6844  
F 03 9417 6855  
www.aspect-studios.com  
melbourne@aspect-studios.com  
ABN 11 120 219 561  
MELBOURNE

**CLIENT**  
MIRVAC  
Level 5, Building Q3  
6 Riverside Quay  
Southbank VIC 3006

**PROJECT**  
Smiths Lane  
Fencing Design Guide

**STATUS**  
DETAIL DESIGN  
NOT FOR CONSTRUCTION

**DRAWING**  
Fencing Details  
Sheet 2

**DRAWN** BF  
**CHECKED** AMP  
**SCALE** A1 | SCALE 1:10  
**DRAWING NO.** M19007-02-LA-003  
**REVISION** A1

Casey Planning Scheme Endorsed in accordance with condition(s) 21 on 11/09/2020 under Permit No. PinA00824/19 Sheet 16 of 27 by slorenzo



**NOTE:**  
TO BE CONSTRUCTED BY MIRVAC

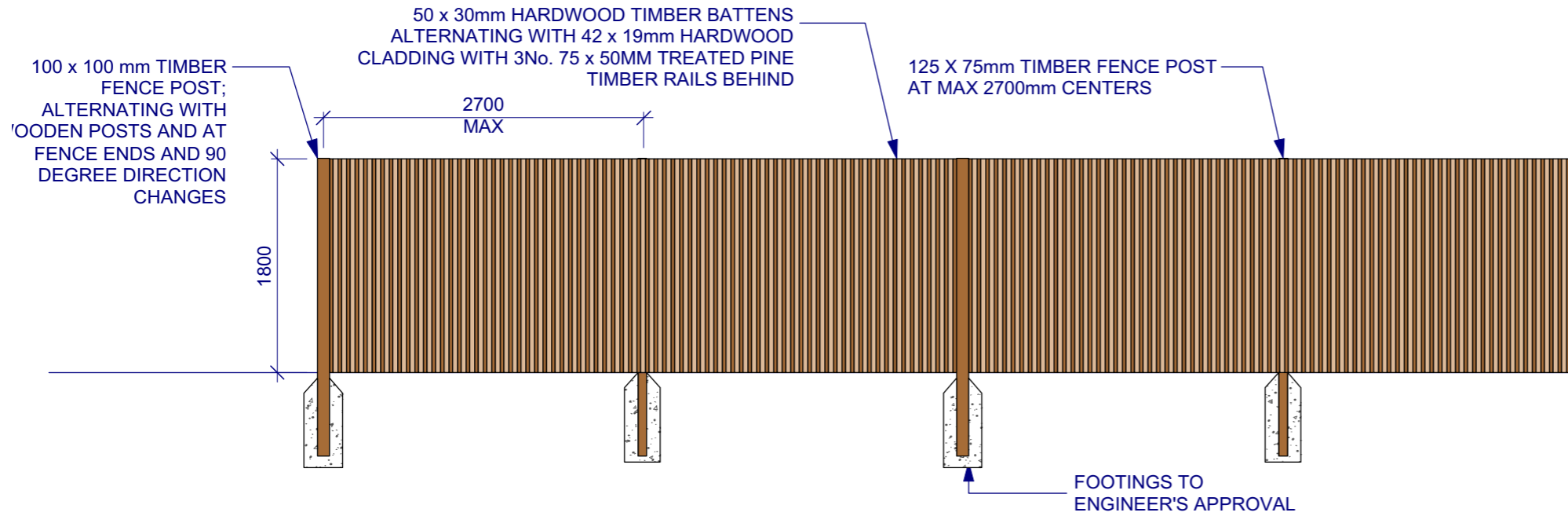

1 Feature Fence Adjacent Open Space - Elevation  
SCALE: 1:50

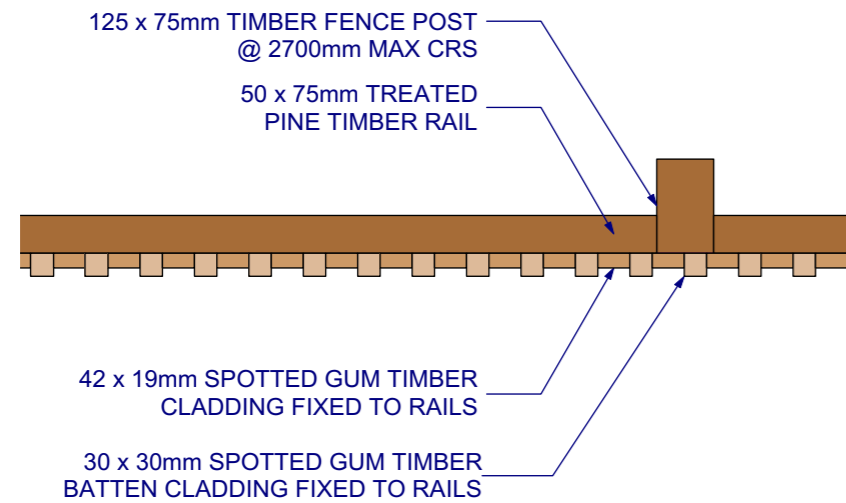

2 Feature Fence Adjacent Open Space- Plan  
SCALE: 1:10

FENCE TO END A MINIMUM OF 4m BEHIND FRONT WALL

FEATURE FENCING TO BE CONSTRUCTED BY MIRVAC IN SELECT LOCATIONS

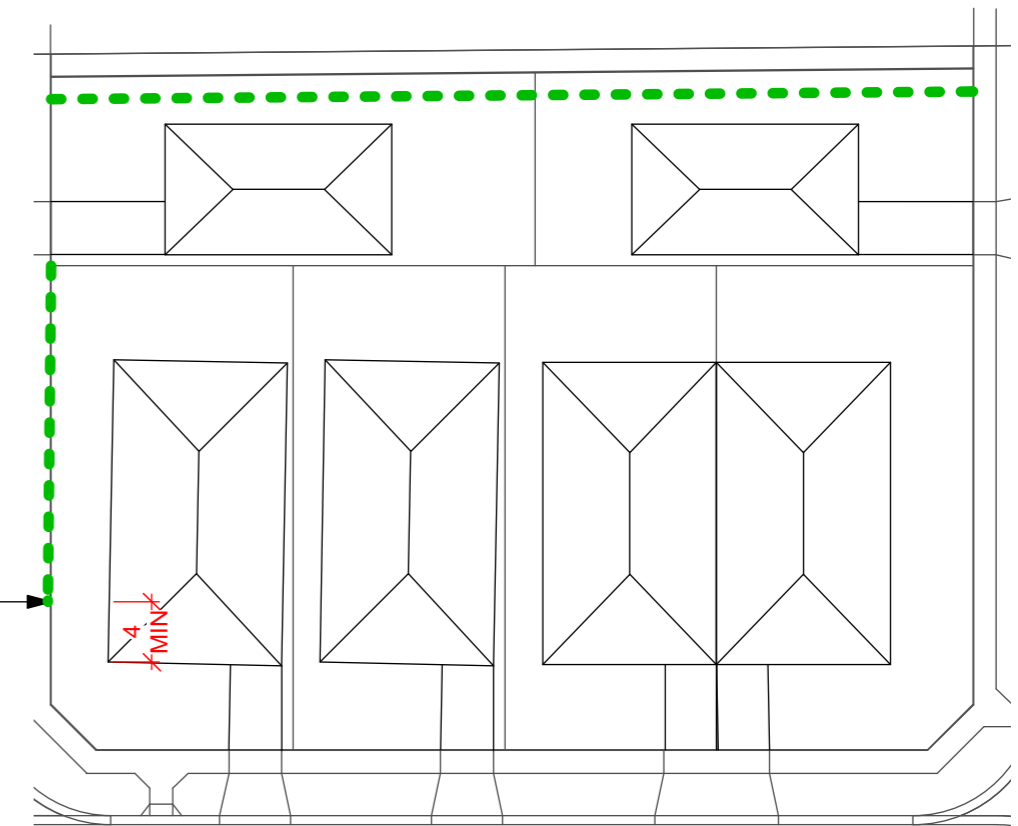

3 LOCATION PLAN  
SCALE: 1:500



**NOTES**  
Check all dimensions and site conditions prior to commencement of any work, the purchasing or ordering of any materials, fitting, plant services or equipment and the fabrication of any components.  
Do not scale drawings - refer to figured dimensions only. Any discrepancies shall immediately be referred to the landscape architect for clarification.  
All drawings may not be reproduced or distributed without prior permission from the landscape architect.

DATE	REV	AMENDMENTS
16.10.2019	A1	DETAIL DESIGN

**ASPECT Studios™**  
ASPECT Studios Pty Ltd  
Level 4, 160 Queen Street  
Melbourne VIC 3000  
Australia  
T 03 9417 6844  
F 03 9417 6855  
www.aspect-studios.com  
melbourne@aspect-studios.com  
ABN 11 120 219 561

**CLIENT**  
MIRVAC  
Level 5, Building Q3  
6 Riverside Quay  
Southbank VIC 3006

**PROJECT**  
Smiths Lane  
Fencing Design Guide

**STATUS**  
DETAIL DESIGN  
NOT FOR CONSTRUCTION

**DRAWING**  
Fencing Details  
Sheet 3

**DRAWN** HF  
**CHECKED** AMP  
**SCALE** A1 | SCALE 1:50  
**DRAWING NO.** M19007-02- LA-004  
**REVISION** A1

**NOTE:**  
TO BE CONSTRUCTED BY PURCHASER ON  
CORNER LOTS WITH NO FEATURE FENCING

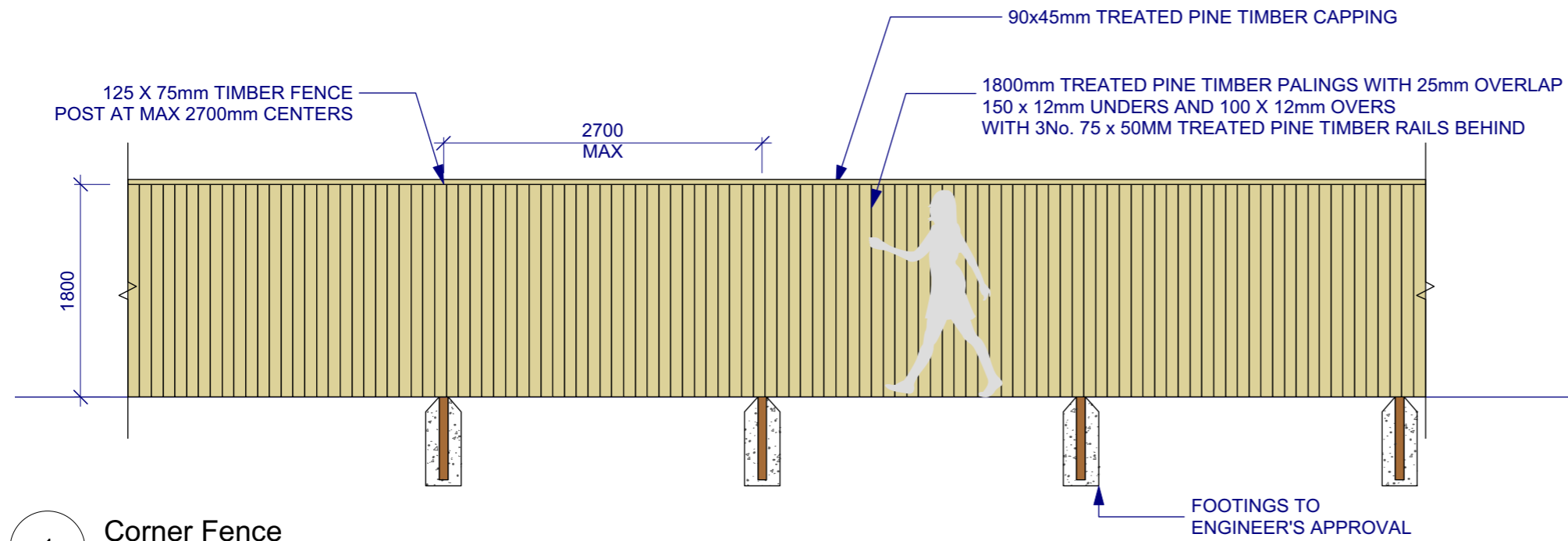

1 **Corner Fence**  
SCALE: 1:50

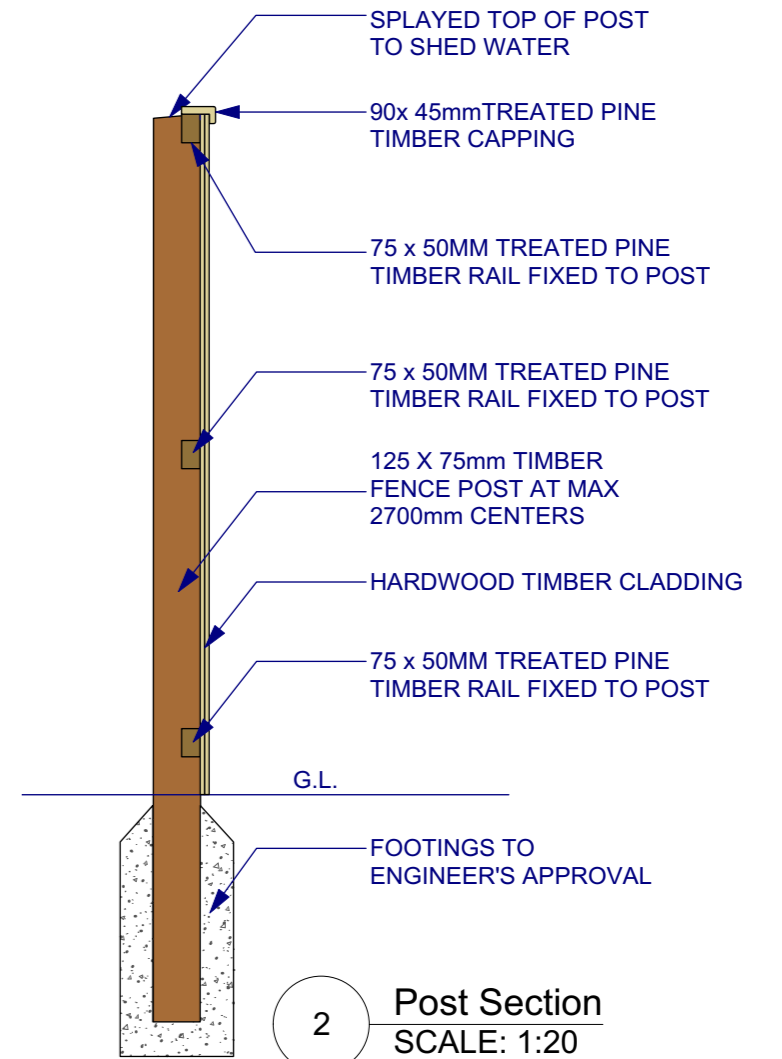

2 **Post Section**  
SCALE: 1:20

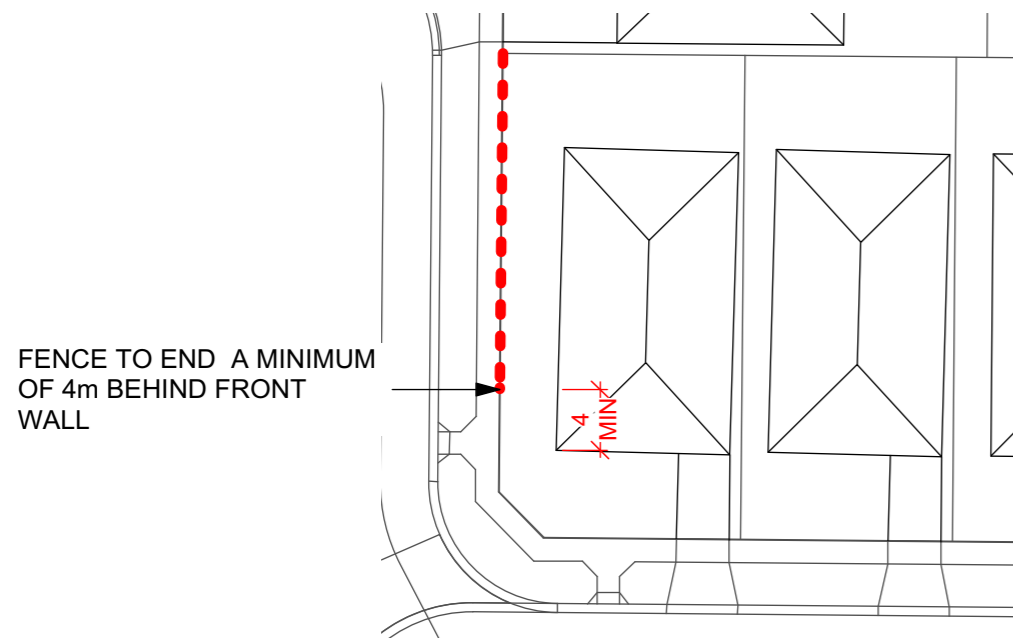

3 **Corner Fence Return - Location Plan**  
SCALE: 1:500



**NOTES**

Check all dimensions and site conditions prior to commencement of any work, the purchasing or ordering of any materials, fitting, plant services or equipment and the fabrication of any components.

Do not scale drawings - refer to figured dimensions only. Any discrepancies shall immediately be referred to the landscape architect for clarification.

All drawings may not be reproduced or distributed without prior permission from the landscape architect.

DATE	REV	AMENDMENTS
16.10.2019	A1	DETAIL DESIGN

**ASPECT Studios™**  
ASPECT Studios Pty Ltd  
Level 4, 160 Queen Street  
Melbourne VIC 3000  
Australia  
T 03 9417 6844  
F 03 9417 6855  
www.aspect-studios.com  
melbourne@aspect-studios.com  
ABN 11 120 219 561

**CLIENT**  
**MIRVAC**  
Level 5, Building Q3  
6 Riverside Quay  
Southbank VIC 3006

**PROJECT**  
Smiths Lane  
Fencing Design Guide

**STATUS**  
DETAIL DESIGN  
NOT FOR CONSTRUCTION

**DRAWING**  
Fencing Details  
Sheet 4

**DRAWN** HF  
**CHECKED** AMP  
**SCALE** A1 | SCALE 1:50  
**DRAWING NO.** M19007-02- LA-005  
**REVISION** A1

**NOTE:**  
TO BE CONSTRUCTED BY PURCHASER

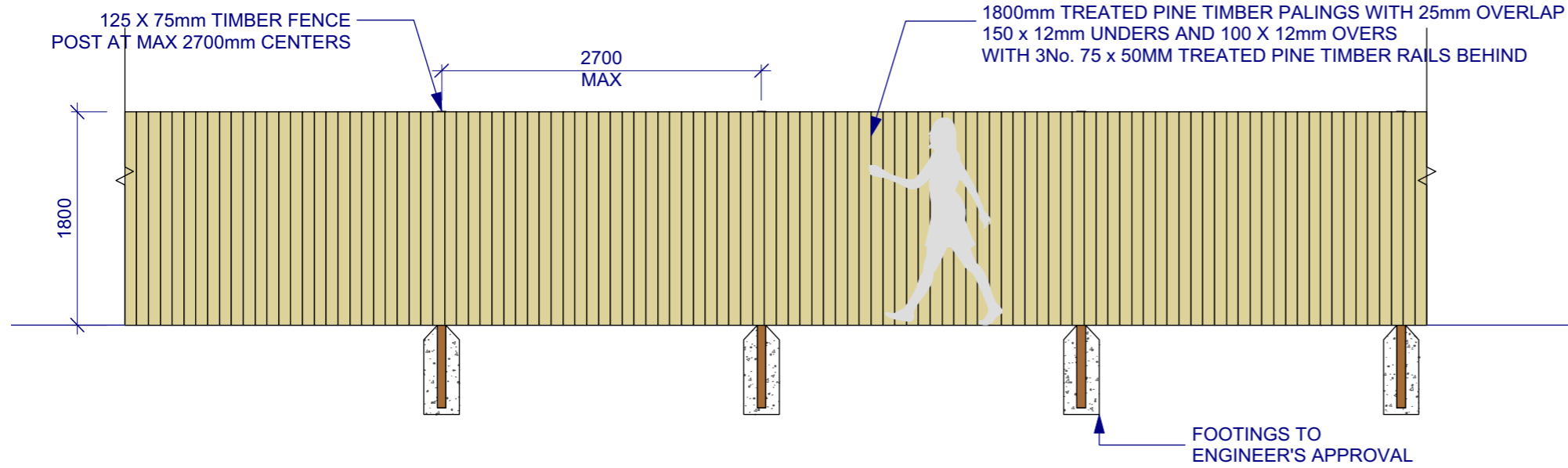

1 Inter Lot Boundary & Rear Boundary Fence  
SCALE: 1:50

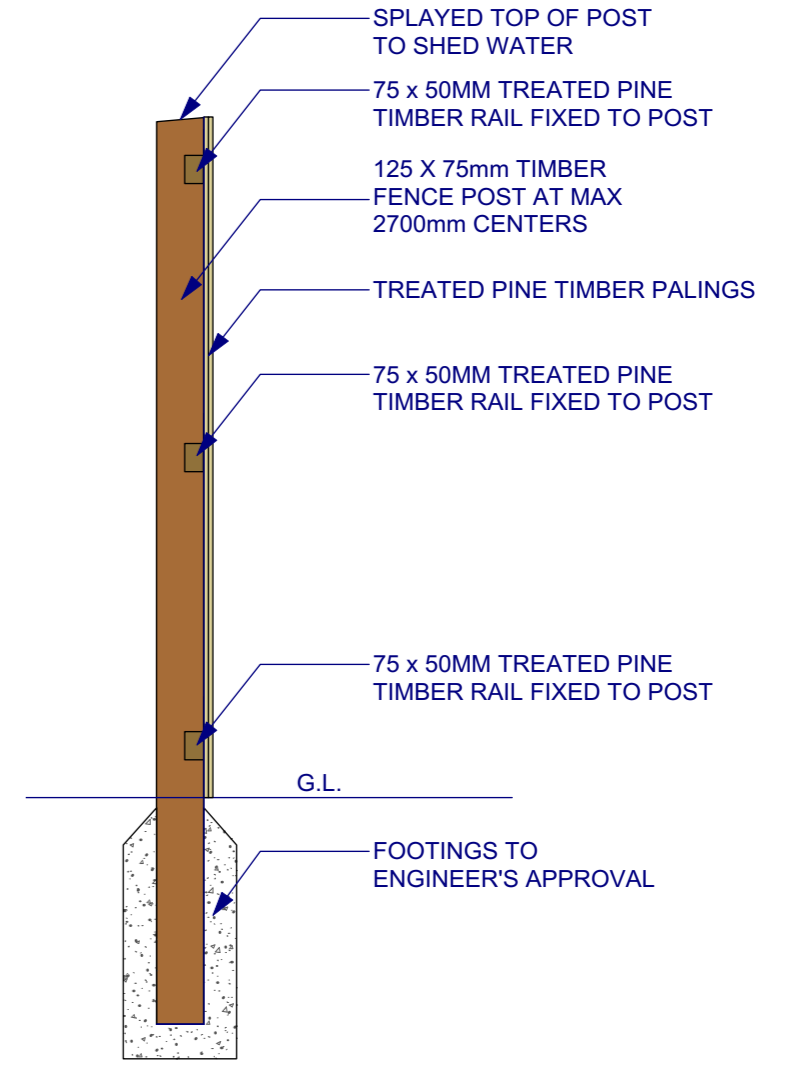

2 Post Section  
SCALE: 1:20

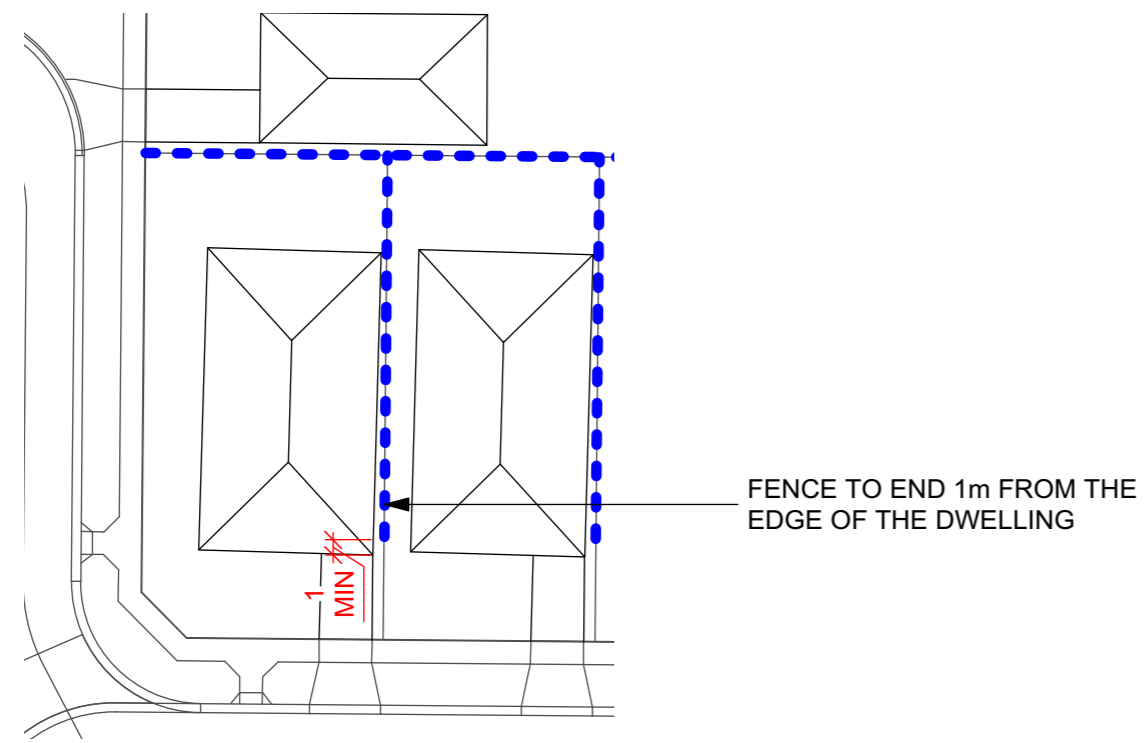

3 Location Plan  
SCALE: 1:500



**NOTES**

Check all dimensions and site conditions prior to commencement of any work, the purchasing or ordering of any materials, fitting, plant services or equipment and the fabrication of any components.

Do not scale drawings - refer to figured dimensions only. Any discrepancies shall immediately be referred to the landscape architect for clarification.

All drawings may not be reproduced or distributed without prior permission from the landscape architect.

DATE	REV	AMENDMENTS
16.10.2019	A1	DETAIL DESIGN

**ASPECT Studios™**  
ASPECT Studios Pty Ltd  
Level 4, 160 Queen Street  
Melbourne VIC 3000  
Australia  
T 03 9417 6844  
F 03 9417 6855  
www.aspect-studios.com  
melbourne@aspect-studios.com  
ABN 11 120 219 561

MELBOURNE

CLIENT  
**MIRVAC**  
Level 5, Building Q3  
6 Riverside Quay  
Southbank VIC 3006

PROJECT  
Smiths Lane  
Fencing Design Guide

STATUS  
DETAIL DESIGN  
NOT FOR CONSTRUCTION

DRAWING  
Fencing Details  
Sheet 5

DRAWN  
HF

CHECKED  
AMP

SCALE A1 | SCALE  
1:50

REVISIONS

M19007-02- LA-006 A1

Casey Planning Scheme Endorsed in accordance with condition(s) 21 on 11/09/2020 under Permit No. PinA00824/19 Sheet 19 of 27 by slorenzo

NOTE:  
TO BE CONSTRUCTED BY PURCHASER

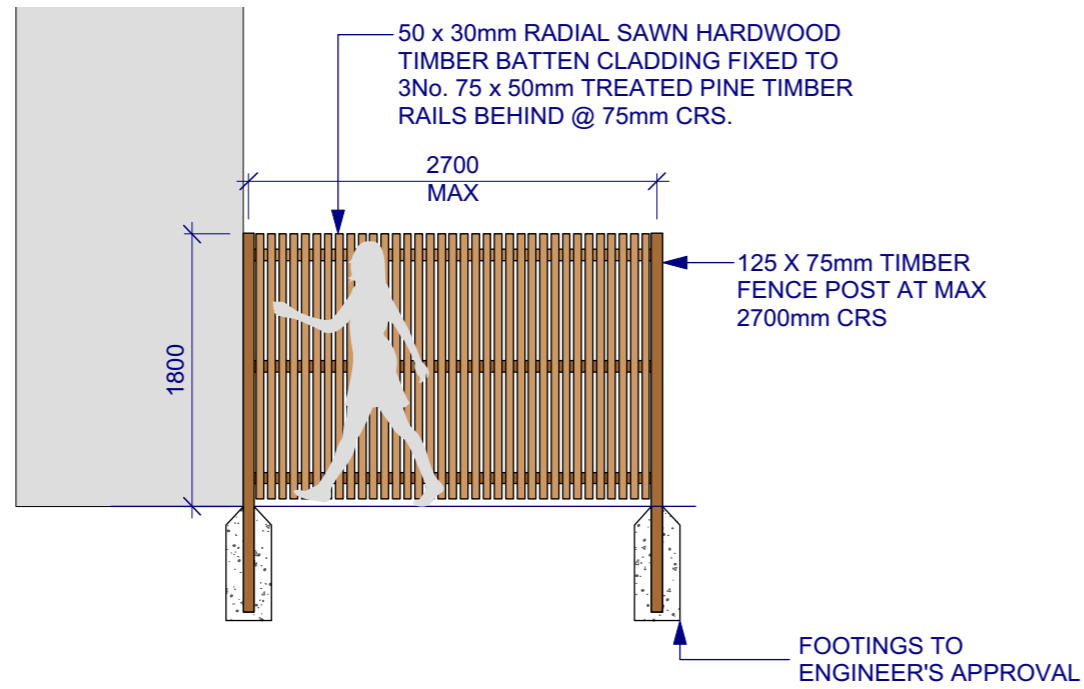

1 Permeable Side Fence to Dwelling - Elevation  
SCALE: 1:50

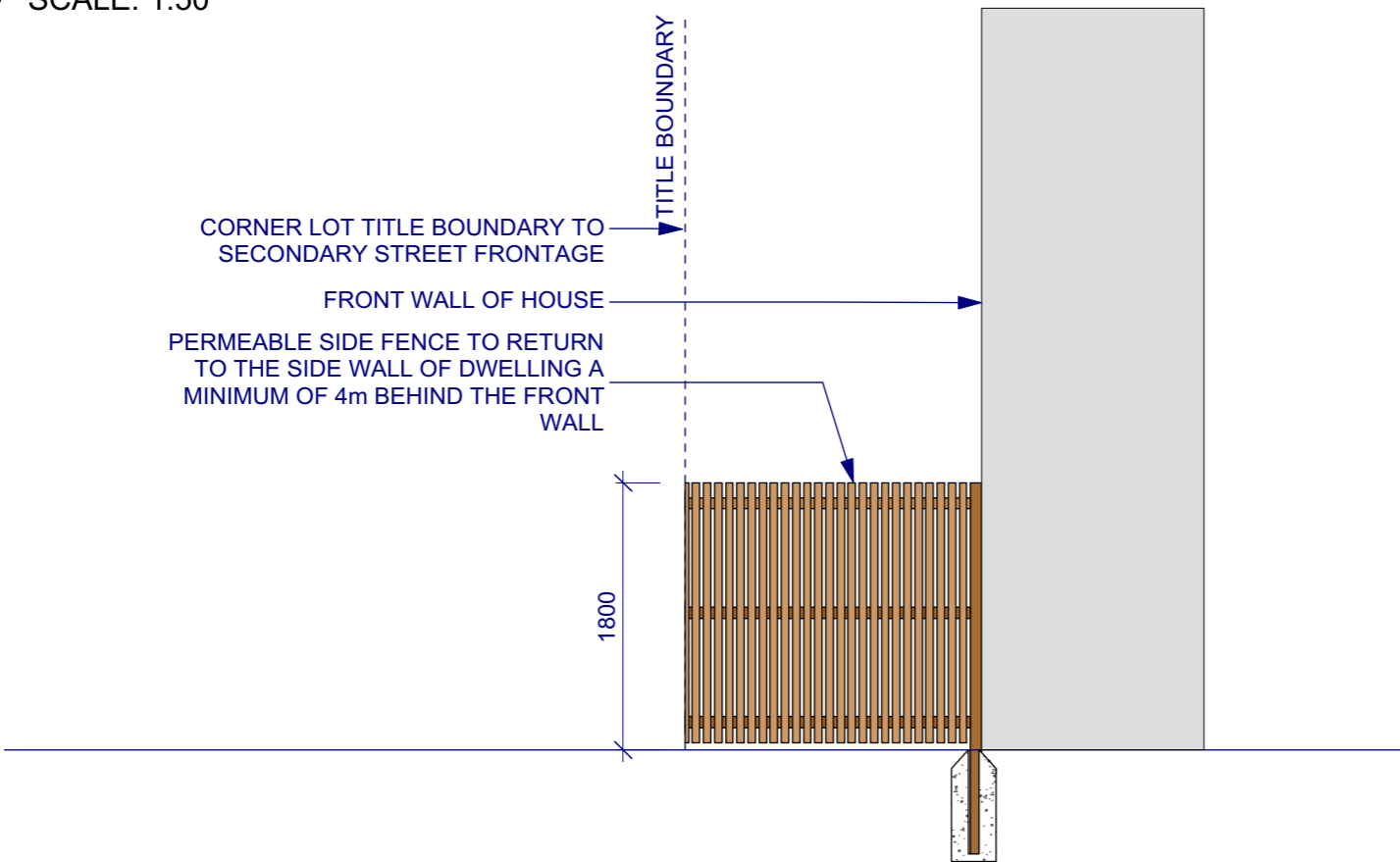

3 Permeable Side Fence to Dwelling - Elevation  
SCALE: 1:50

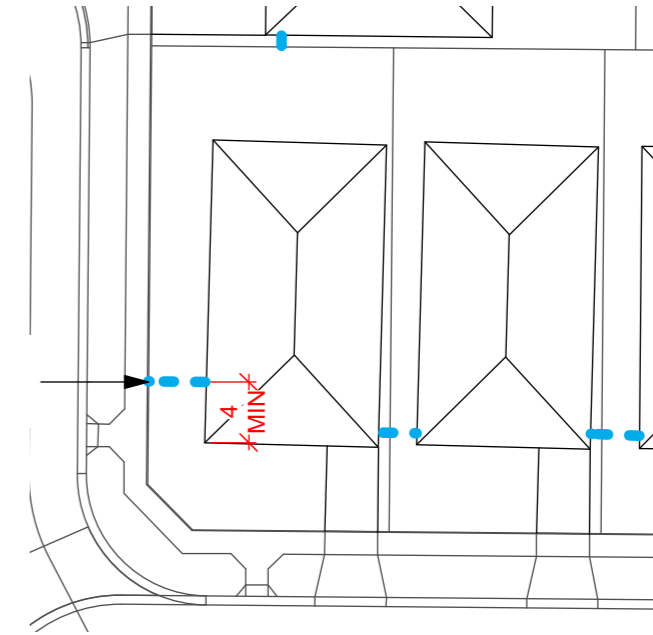

FENCE TO BE SET A  
MINIMUM OF 4m BEHIND  
FRONT WALL

2 Permeable Side Fence to Dwelling - Plan  
SCALE: 1:500

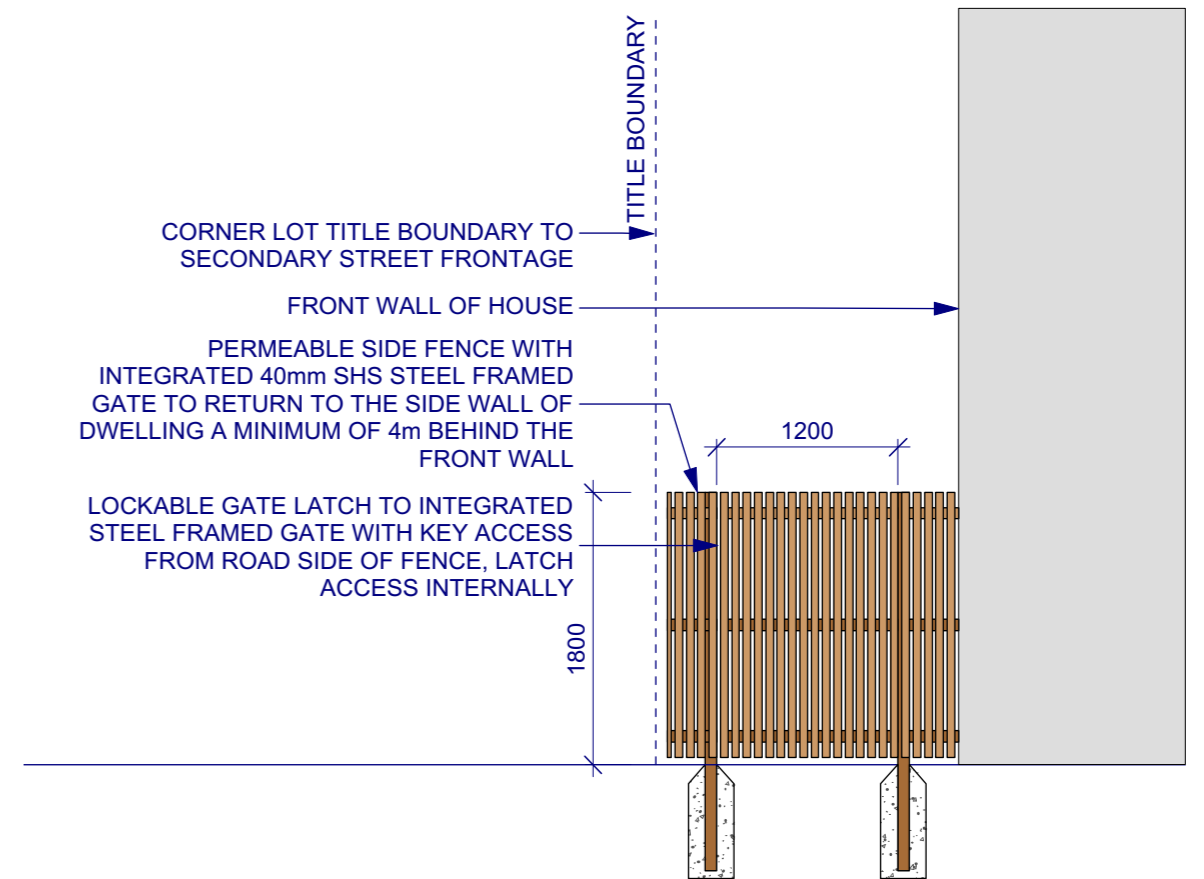

4 Permeable Side Fence to Dwelling - Elevation  
SCALE: 1:50



**NOTES**  
Check all dimensions and site conditions prior to commencement of any work, the purchasing or ordering of any materials, fitting, plant services or equipment and the fabrication of any components.  
Do not scale drawings - refer to figured dimensions only. Any discrepancies shall immediately be referred to the landscape architect for clarification.  
All drawings may not be reproduced or distributed without prior permission from the landscape architect.

DATE	REV	AMENDMENTS
16.10.2019	A1	DETAIL DESIGN

**ASPECT Studios™**  
ASPECT Studios Pty Ltd  
Level 4, 160 Queen Street  
Melbourne VIC 3000  
Australia  
T 03 9417 6844  
F 03 9417 6855  
www.aspect-studios.com  
melbourne@aspect-studios.com  
ABN 11 120 219 561

**CLIENT**  
**MIRVAC**  
Level 5, Building Q3  
6 Riverside Quay  
Southbank VIC 3006

MELBOURNE

**PROJECT**  
Smiths Lane  
Fencing Design Guide

**STATUS**  
DETAIL DESIGN  
NOT FOR CONSTRUCTION

**DRAWING**  
Fencing Details  
Sheet 6

**DRAWN** HF  
**CHECKED** AMP  
**SCALE** A1 | SCALE 1:50  
**DRAWING NO.** M19007-02-LA-007  
**REVISION** A1

Casey Planning Scheme Endorsed in accordance with condition(s) 21 on 11/09/2020 under Permit No. PinA00824/19 Sheet 20 of 27 by slorenzo

NOTE:  
TO BE CONSTRUCTED BY PURCHASER

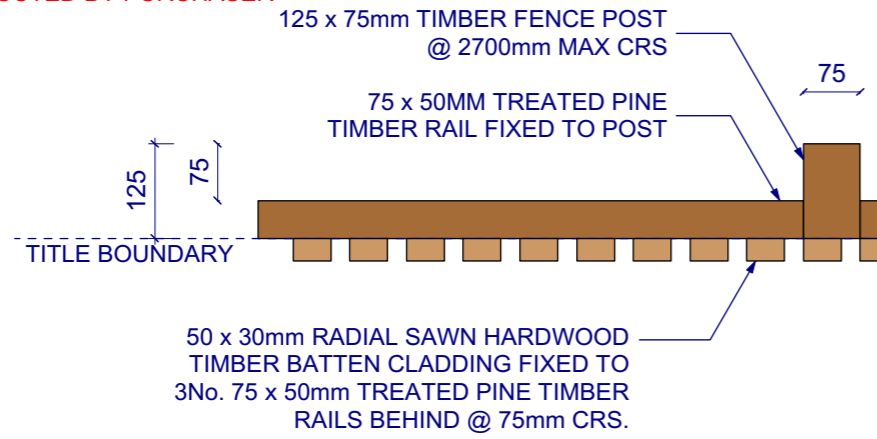

1 Permeable Side Fence - Plan  
SCALE: 1:10

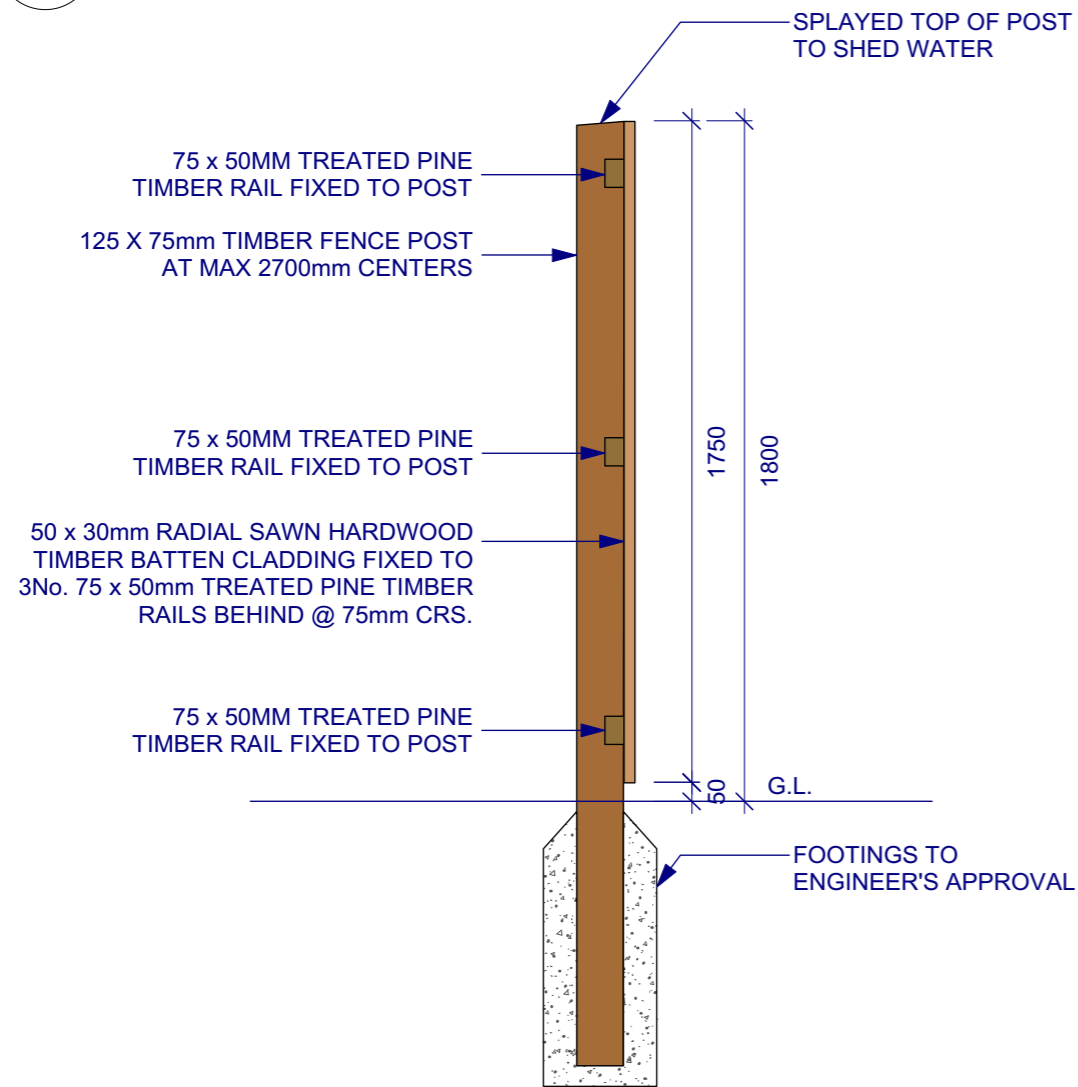

2 Post Section  
SCALE: 1:20

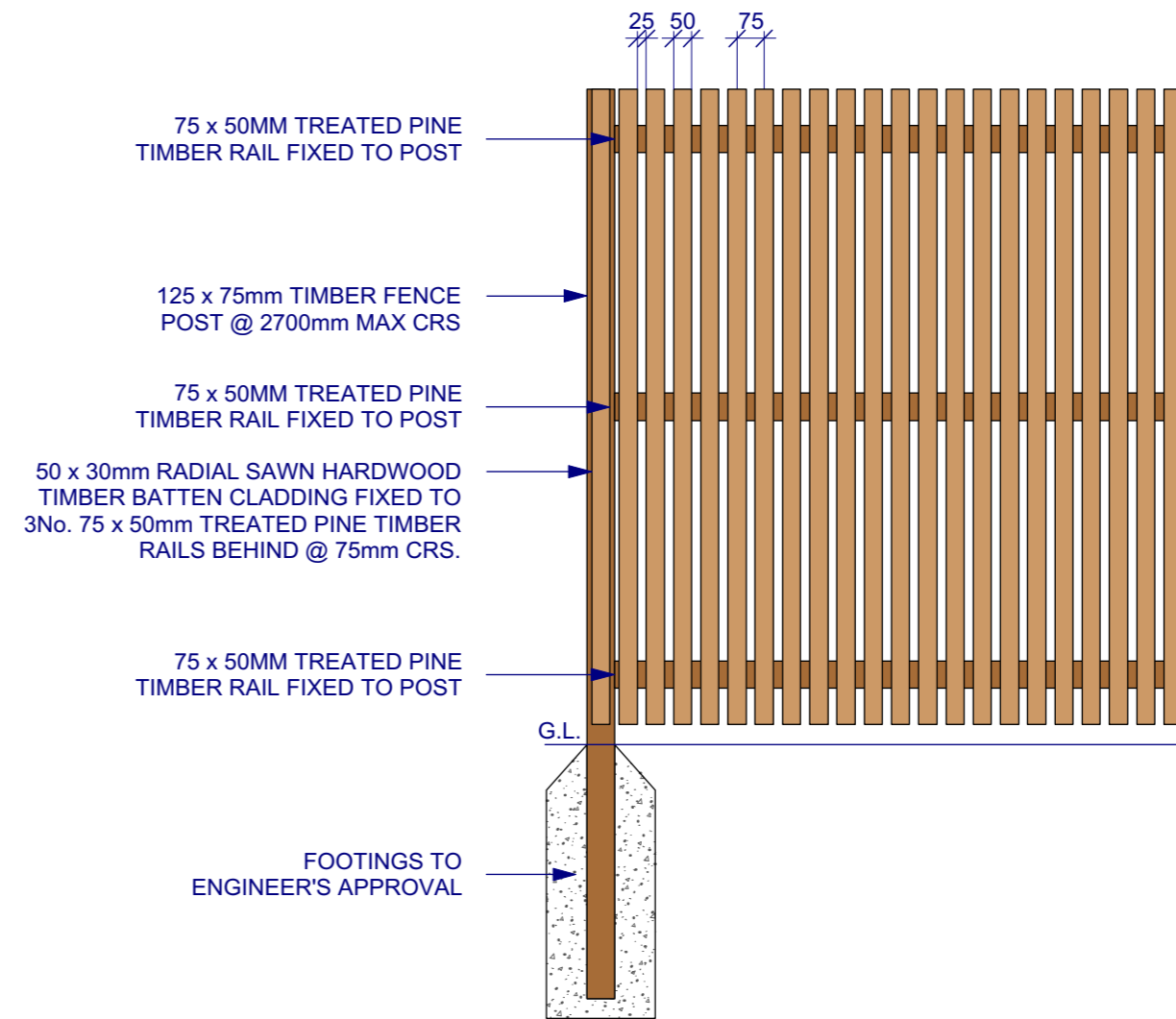

3 Permeable Side Fence to Dwelling - Section  
SCALE: 1:20



**NOTES**  
Check all dimensions and site conditions prior to commencement of any work, the purchasing or ordering of any materials, fitting, plant services or equipment and the fabrication of any components.  
Do not scale drawings - refer to figured dimensions only. Any discrepancies shall immediately be referred to the landscape architect for clarification.  
All drawings may not be reproduced or distributed without prior permission from the landscape architect.

DATE	REV	AMENDMENTS
16.10.2019	A1	DETAIL DESIGN

**ASPECT Studios™**  
ASPECT Studios Pty Ltd  
Level 4, 160 Queen Street  
Melbourne VIC 3000  
Australia  
T 03 9417 6844  
F 03 9417 6855  
www.aspect-studios.com  
melbourne@aspect-studios.com  
ABN 11 120 219 561

CLIENT  
**MIRVAC**  
Level 5, Building Q3  
6 Riverside Quay  
Southbank VIC 3006

PROJECT  
Smiths Lane  
Fencing Design Guide

STATUS  
DETAIL DESIGN  
NOT FOR CONSTRUCTION

DRAWING  
Fencing Details  
Sheet 7

DRAWN  
HF  
CHECKED  
AMP  
SCALE A1 | SCALE  
1:50  
DRAWING NO.  
M19007-02- LA-008  
REVIS  
A1

APPENDIX 4:  
FENCING CONSENT FORM

## SMITHS LANE FENCING CONSENT FORM

### PROPERTY OWNER CONTACT DETAILS

- I consent to Mirvac providing my contact details upon request to an owner of any property abutting my own for the purposes of arranging for installation of fencing on property boundaries.

\*Note: Fencing costs are typically shared between adjoining lot owners

Preferred Contact Name \_\_\_\_\_

Contact Phone Number \_\_\_\_\_

Email \_\_\_\_\_

Signed \_\_\_\_\_

Purchaser Name(s) \_\_\_\_\_

Lot Number \_\_\_\_\_

Mirvac will not provide your contact information to any other party without your prior consent

Fencing must comply with the Smiths Lane Design Guidelines and relevant Council requirements. For more information on external finishes for your home please refer to the Smiths Lane Design Guidelines.

APPENDIX 5:  
LANDSCAPING REQUEST FORM



## LANDSCAPE REQUEST FORM

This checklist must be submitted with your Design Assessment Application.

This form is to be submitted to Mirvac as part of the Design Review submission as required if you have opted to take up Mirvac's offer to provide complementary landscaping to the front of your lot.

Completed forms can be emailed to Victoria Settlements team at vic.settlements@mirvac.com or posted to:

**Smiths Lane Customer Relations**  
**Mirvac**  
**Level 5, Q3, 6 Riverside Quay, Southbank 3006**

Mirvac will inspect your lot and will endeavour to install your selected landscape within 3 months of receiving your Certificate of Occupancy, provided you have complied with all requirements.

**Please note: we do not customise gardens on request. The installation is in accordance with the style chosen, species' availability & suitability at time of installation and the geometry of your lot.**

Lot No. \_\_\_\_\_ Date: \_\_\_\_\_

Owner's Name \_\_\_\_\_ Preferred Contact No. \_\_\_\_\_

**Selected landscape style (refer to landscape options for indicative designs and plant species)**

Contemporary Cottage Garden     Native Garden     Kitchen Garden     Resilient Garden

**Selected landscape design to be executed and submitted as part of this application.**

- I acknowledge the following works to be complete prior to handing over the front yard to Mirvac for landscaping
- Driveway complete
  - All required earthworks complete
  - Retaining walls complete (if applicable) and in accordance with the Design Guidelines, section 10.3. (if batter is to be used, it should not be more than 1:6 gradient - consult your builder architect)
  - Irrigation system installed (if applicable) - please provide as-constructed plans
  - Landscape area leveled to 100mm below driveway level in preparation for top soil
  - External water top and adjacent external power supply installed as per Design Guidelines, section 11.2.2
  - All site rubbish removed
  - Garage door installed
  - Porch and footpaths complete
  - Fencing installed
  - Letterbox installed
  - Drainage infrastructure installed (as required)
  - NBN Co. street connection completed
  - Clear access to area in which works will be undertaken

\*Note - Retain a copy of the checklist for your reference to ensure all works are completed

Please refer to selected landscape style design for a breakdown of requirements.

By submitting this form to Mirvac I acknowledge the following:

- I intend to take up Mirvac's offer of providing landscaping to the front of my lot and grant Mirvac and all related contractors access to my lot for the purpose for this purpose.
- House design will be constructed in accordance with the Design Guidelines.

Signed (owner) \_\_\_\_\_ Date: \_\_\_\_\_

Once you have completed your home, please send through an email request to vic.settlements@mirvac.com with your name, lot number and a message confirming all works listed above have been completed. Mirvac will then inspect your lot and endeavour to install your selected front garden within 3 months of receiving your request, provided you have complied with all requirements.

## TERMS AND CONDITIONS

The Owner acknowledges and accepts that in the case that Landscaping is procured by Mirvac:

- a) the composition and extent of such Landscaping will be in accordance with the agreed landscaping plans and will be adjusted to suit specific geometry of the property, sunlight and shade conditions, species availability & suitability at the time and will be at the discretion of Mirvac;
- b) the Landscaping will be carried out at the discretion of Mirvac by a contractor or contractors nominated by Mirvac; and
- c) the risk of all Landscaping (including but not limited to theft of plants or reticulation components, damage to any garden kerbing and the health of all plants and lawn areas) will be at the risk of the Owner from the date that the Landscaping commences.

The Owner grants to Mirvac and its respective contractors a licence to access the Property for the purposes of completing the Landscaping and grants Mirvac the right to provide their contact details to its respective contractors for the purpose of arranging landscape installation.

If the Owner does not submit a Landscape Request Form, the Owner must complete the landscaping of the Property in accordance with the Smiths Lane Design Guidelines within 6 months of the issue of a Certificate of Occupancy for the dwelling on the Property.

[SMITHSLANE.MIRVAC.COM](http://SMITHSLANE.MIRVAC.COM)